



Most Trusted Traveling Irrigation Systems
Since 1964

Kifco Model E110 Water-Reel®



- DC Electric Driven Water-Reel® with 1.1" ID x 280' MDPE Tube (Battery not included)
- Simple, reliable, portable irrigation for pastures, paddocks, riding arenas, sports fields, vegetables and residential settings
- Automatic shutoff allows for unattended operation
- Mechanical levelwind system with miswrap safety for uniform, reliable tube rewinding
- Rugged construction proven by over 40 years of production and over 35,000 Kifco Water-Reels® sold
- Industry leading products with service and distribution at over 200 authorized dealers

Applicable Markets



Horse Arenas



Pastures & Paddocks



Residential Landscape,
Gardens & Nurseries



Sports Fields

Standard Features and Benefits

- The Kifco Model E110 uses a DC electric retraction motor and can operate as low as 23 psi and 3 gpm for up to 40 hours on a full charge (Battery not included)
- Optional solar panel is available for hassle free outdoor use
- Sprinkler selector valve easily allows for automatic sprinkler shutoff at the end of the run or continued operation
- Two large flotation tires make transport by hand or small garden tractor simple

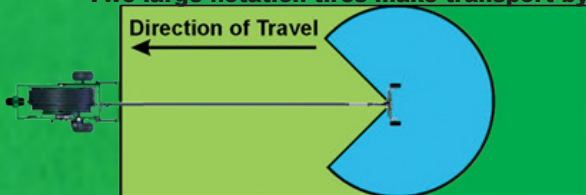

Easy Operation

1 Year
Manufacturer's Warranty
5 Year
Pro-Rated Tube Warranty
Operator & Parts
manuals available at
www.kifco.com

Local Parts & Service



American Society of Agricultural & Biological Engineers

AE50

Inspired Ideas!
Outstanding Innovations!
Best of the Year!



Engineered in the USA



www.kifco.com



700 S. Schrader Ave.
P.O. Box 290
Havana, IL 62644
800-452-7017 Toll Free
309-543-4425 Phone
309-543-4945 Fax

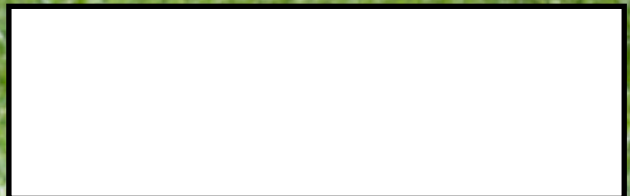

E110 Dimensions - B2 Chassis

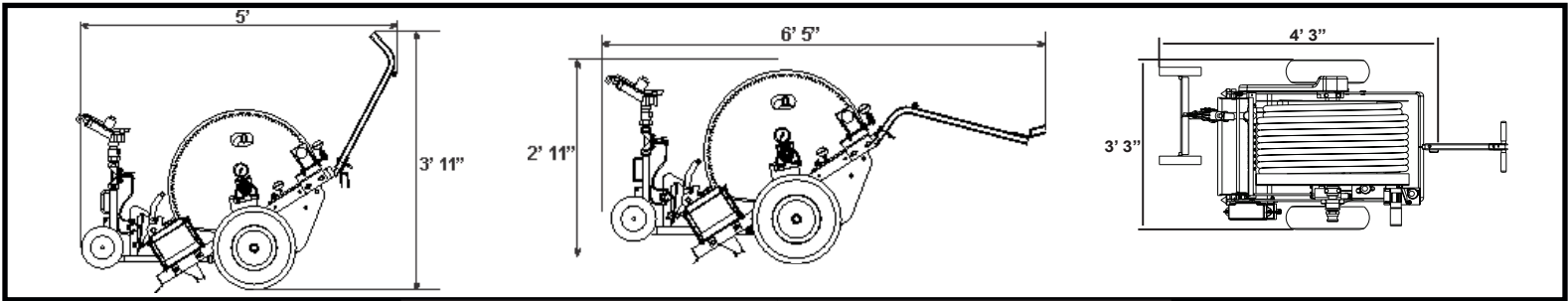

Sprinkler Diagram

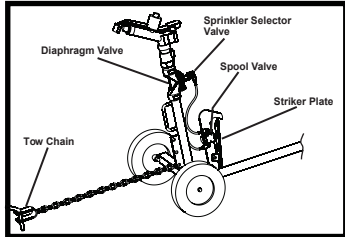

Mechanical Levelwind System

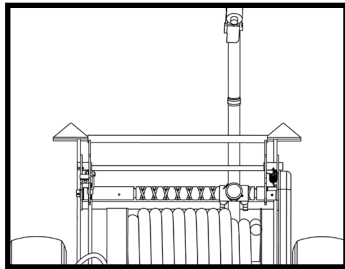

Technical Specifications

Tube Inner Diameter/Length	1.1" x 280'
Irrigated Width	58' - 110'
Irrigated Length	309' - 335'
Irrigated Area Per Run (Acres)	0.4 - 0.8
Drive System	DC Electric Motor
GPM Range	3 - 26
Inlet PSI Range	23 - 100
Hours Per Full Run	1.75 - 9.3
Retraction Speed	30' - 160'
Dry Weight (lbs)	300
Weight With Water (lbs)	369
Inlet Diameter	1.5" Male Camlock
Supply Hose	15' 1.5" Male x Female Camlock
Options	
Solar Panel Kit	Eliminates the need for AC charge
Booster Pump	1Hp Electric (cannot be Reel mounted)
Primary Pump	5.5Hp Gas, 9Hp Gas
Battery & Trickle Charger Kit	12 v battery and charger

Standard Connection

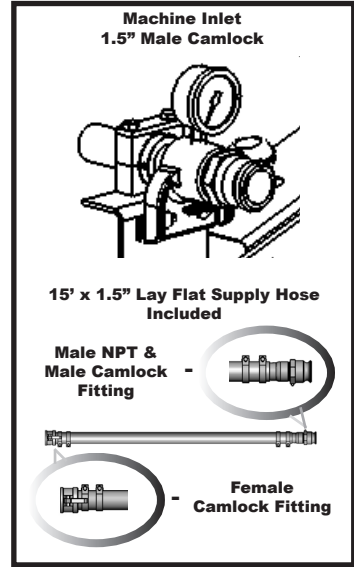

Sprinkler Performance

Sprinkler Model	Nozzle Dia.	Inlet PSI	(Q) GPM	Width (ft.) (80%)	Length (ft.) (80%)	Wetted Dia. (ft.)	Application Rate (in.)
Sime K1	6mm	26	7	68	314	85	0.06 - 0.33
	6mm	47	9	77	318	96	0.07 - 0.38
	6mm	68	12	86	323	108	0.08 - 0.45
	7mm	50	13	80	320	100	0.10 - 0.52
	7mm	75	16	90	325	112	0.11 - 0.57
	8mm	53	16	94	327	118	0.10 - 0.54
	8mm	87	21	108	334	135	0.12 - 0.63
	9mm	53	19	92	326	115	0.12 - 0.66
	9mm	100	26	110	335	138	0.14 - 0.76

Sprinkler Model	Nozzle Dia.	Inlet PSI	(Q) GPM	Width (ft.) (80%)	Length (ft.) (80%)	Wetted Dia. (ft.)	Application Rate (in.)
Sime Silver	4mm	23	3	58	309	72	0.03 - 0.17
	4mm	45	4	68	314	85	0.04 - 0.19
	4mm	60	5	78	319	98	0.04 - 0.20
	5mm	48	7	73	317	92	0.06 - 0.31
	5mm	63	8	84	322	105	0.06 - 0.32
	6mm	52	10	78	319	98	0.08 - 0.42
	6mm	68	12	86	323	108	0.08 - 0.44

Area covered may vary depending on wind conditions and use of different sprinklers. Specifications are subject to change without notice. Technical specifications contained herein are based upon sprinkler manufacturer's recommended pressure and flow. Actual specifications may vary.

The K1 8 degree sprinkler is also an option for the E110

The E-110 Water-Reel is the perfect solution for both your indoor and outdoor arenas

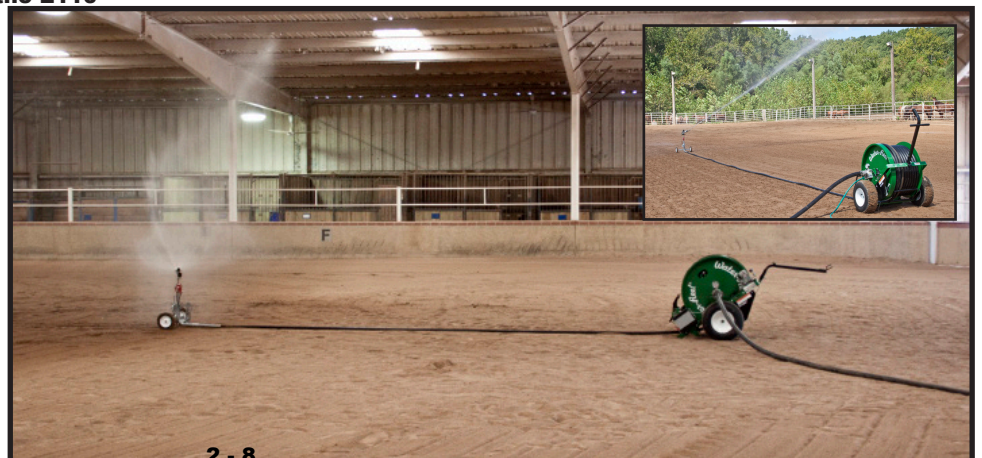

Revised 03/18